

SDGR SPIRAL DUCT GRILLE RETURN

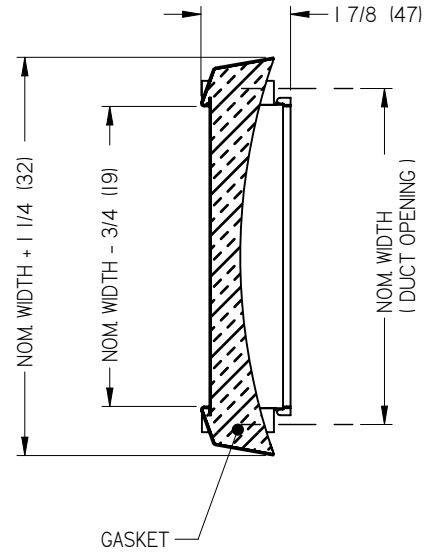
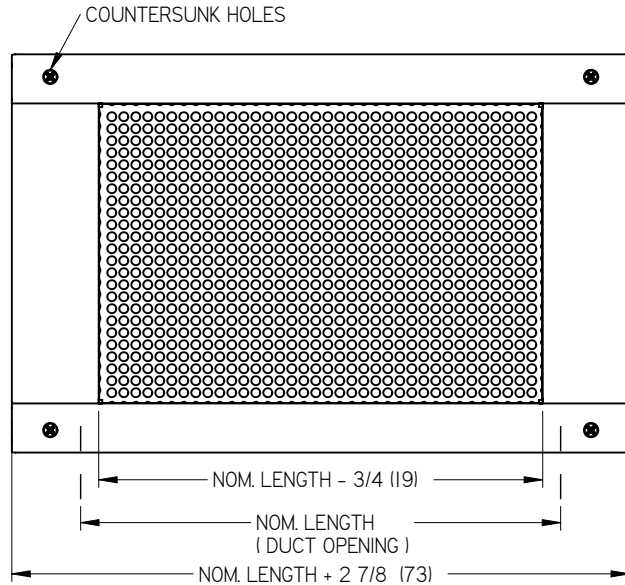

RECOMMENDED SDGR SIZE FOR SPECIFIED DUCT DIAMETER		
DUCT SIZE (DIAMETER)	MINIMUM NOM. WIDTH SIZE	MAXIMUM NOM. WIDTH SIZE
8" - 13"	-	4"
14" - 21"	4"	6"
22" - 31"	4"	8"
32" - 41"	4"	10"
42" - OVER	4"	12"

OPTIONS:

GASKET GREY WHITE BLACK

MATERIAL:

ST STEEL
 GV GALVANIZED

FINISH:

B12 WHITE (ST)
 (OTHER FINISHES AVAILABLE)
 GV MILL FINISH

NOTES:

- INTENDED FOR USE IN SPIRAL OR ROUND DUCT APPLICATIONS (MINIMUM DUCT SIZE 8" (203))
- MINIMUM NOM. LENGTH IS 10" (254)
- MAXIMUM NOM. LENGTH IS 36" (914)
- AVAILABLE SIZE IN 1" INCREMENTS
- OPEN CELL FOAM INSULATION PROVIDES A TIGHT SEAL AROUND THE GRILLE OPENING IN ANY ROUND DUCT (GREY STANDARD)
- FACTORY TOLERANCE +/- 1/32" (1)
- GALVANIZED UNITS ARE MILL FINISH.

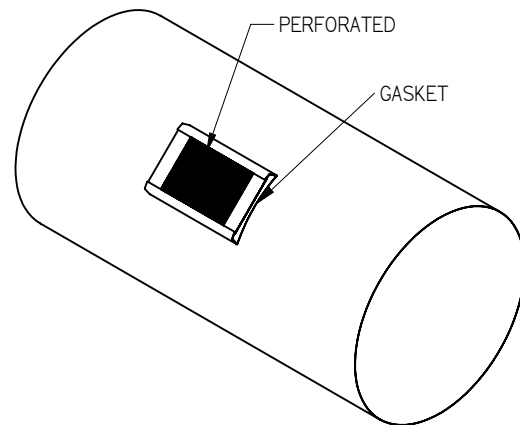

ALL METRIC DIMENSIONS () ARE SOFT CONVERTED. IMPERIAL DIMENSIONS ARE CONVERTED TO METRIC AND ROUNDED TO THE NEAREST MILLIMETER.

PROJECT:		PRICE	SDGR SPIRAL DUCT GRILLE RETURN
ENGINEER:			
CUSTOMER:		248720	
SUBMITTAL DATE:	SPEC. SYMBOL:	MAR. 2008	